

ASHUN

Accumulators |

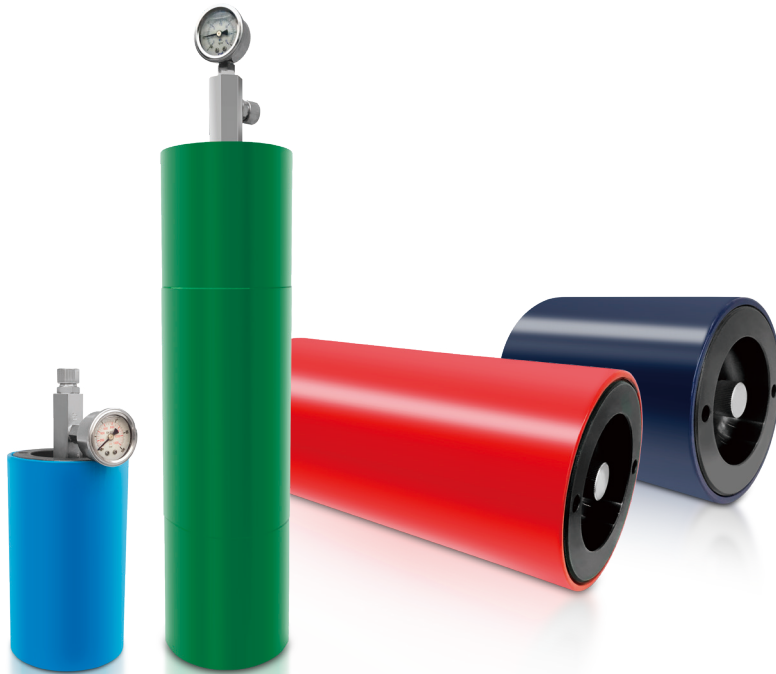

Jan. 2017

油順精密股份有限公司
ASHUN FLUID POWER CO., LTD.

www.ashun.com

A WORLD-CLASS MANUFACTURER

of Piston Accumulators

油順精密成立於1984年，以液壓動力系統設計為企業基礎，多年來致力研發、生產各式油壓、氣壓產品與客製化產品，產品包含：油壓缸、氣壓缸、油壓閥、蓄壓器、油壓動力系統等。

油順精密為客戶在流體傳動產業的第一選擇且透過高性能的解決方式創造價值，以誠信正直、專注創新與責任為宗旨，作為流體傳動產業中，長期且值得信賴的技術及產能提供者。

油順精密致力於培育人才進修，不斷研究開發新產品，更為提升品質穩定性與生產技術，陸續引進德日自動化設備，提升良好的生產管理與品質管制程序，產品品質更加完美。

油順精密產品成功外銷遍及全球，更獲得歐、美、日等工業大國品質認可。展望未來，油順精密將更積極研發新產品，期望邁向國際化，根留台灣，永續經營。

ASHUN was established in 1984. ASHUN is based on fluid power systems, makes efforts to research, develop and manufacture various hydraulic, pneumatic products and customized products. ASHUN products include hydraulic cylinders, pneumatic cylinders, hydraulic valves, accumulators, hydraulic power units, etc.

ASHUN shall be the customers' first choice in the fluid power industry, creating value through high-performance solutions. The core values are integrity, customer focus, innovation and responsibility. Our mission is to be the trusted technology and capacity provider of the fluid power industry for years to come.

ASHUN exerts to train excellent talent, research and develop new products constantly, in order to promote the stability of quality and manufacturing technology, ASHUN has been replenishing automation equipment from Germany and Japan, improved the good manufacturing management and quality control procedures, the quality of products will be more perfect.

ASHUN products are exported worldwide successfully, and access to quality recognition from industrial countries, such as Europe, USA and Japan. Prospect of the future, ASHUN will be more positive to research and develop new products, look forward to moving toward internationalization, the root keeps Taiwan and permanent management.

ACCUMULATOR APPLICATION.....01

A280 Series.....03

B250 Series.....04

C210 Series.....05

D260 Series.....06

CHARGER.....07

Accumulators

活塞式蓄壓器 **Piston**

用途

蓄壓器為流體動力組件，在液壓系統裡可以蓄存能源的方法應該說只有蓄壓器。蓄壓器它有平時將液壓的能源直接蓄存起來，在緊急時即可以使用的獨特優點。

應用

- 蓄存流體能量：瞬間能取得大流量，補償內部的洩漏。
- 脈動的吸收：能使噪音、脈動等減衰。
- 衝擊的減緩：吸收衝擊壓力，具有緩衝器(Shock Absorber)的用途。

FUNCTION

Fluids are practically incompressible and can not therefore store pressure energy.

The compressibility of a gas (nitrogen) is utilized in piston accumulators for storing fluids. ASHUN piston accumulators are based on this principle.

A piston accumulator consists of a fluid section and a gas section with the piston acting as the gas-proof screen. The gas section is pre-charged with nitrogen.

The fluid section is connected to the hydraulic circuit so that the piston accumulator draws in fluid when the pressure increases and the gas is compressed.

When the pressure drops, the compressed gas expands and forces the stored fluid into the circuit.

APPLICATION

ASHUN piston accumulators can be used in a wide variety of applications, some of which are listed below :

Shock absorption; Pulsation dampening; Energy storage.

Emergency operation; Force equilibrium; Leakage compensation; Volume compensation.



Accumulator Application 蓄壓器應用

1. Energy Storage

An Accumulator stores the surplus fluid discharged from a pump, and releases the fluid instantaneously when actuators require oil volume intermittently above the pump discharge capacity.

Therefore, the pump can be miniaturized and the noise and the temperature of hydraulic fluid can be decreased by ON-OFF operation. Moreover, the heat exchanger and the electric facility can also be miniaturized, and generally at least 20% of energy can be saved.

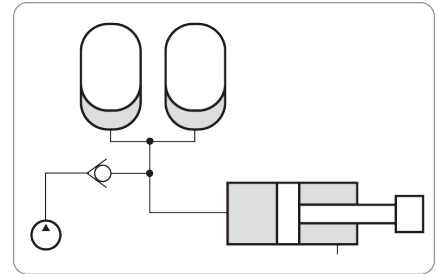

2. Pressure maintenance circuit

Temperature Compensation

In a closed hydraulic system, the volume of fluid expands when there is a rise in system temperature (it shrinks when temperature drops). If the expansion of the fluid is great enough, it may cause damage to the system components. Accumulators can be used to absorb this expansion of the fluid.

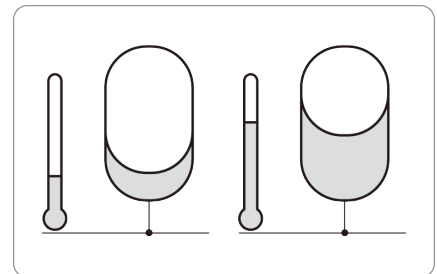

Leakage compensation

An Accumulator can also be used to make up fluid lost through leakage, cold temperatures, and other change in fluid volume. So, the constant system pressure can be obtained.

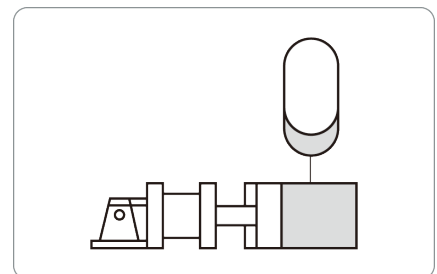

Counter Balance

An Accumulator settled in conjunction with a hydraulic cylinder can be used to absorb energy from the cylinders and acts as a counter balance for a large load.

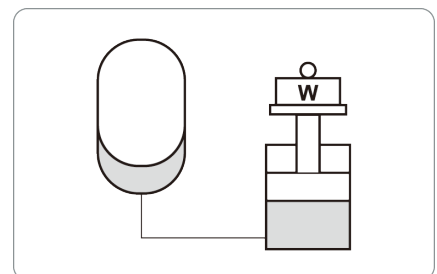

Shock absorption

An Accumulator acts as a gas spring and can be used to absorb shocks between the wheels and the body of a vehicle.

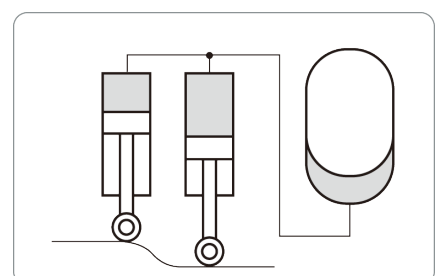

3. Transfer Barrier

A transfer barrier type Accumulator can be used as a substitute for a hydraulic pump by transferring or transmitting fluids, with the bladder being operated as a piston to let a fluid (oil or gas) flow into and out of the Accumulator intermittently.

By adding backup nitrogen gas bottles to the systems, a transfer barrier type Accumulator can discharge a greater volume of fluid even when the difference between the maximum and minimum system pressure is small.

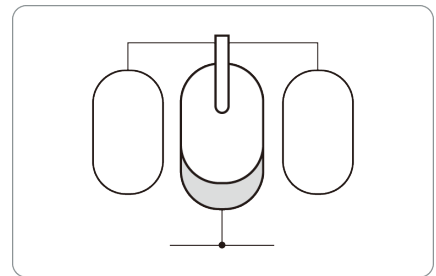
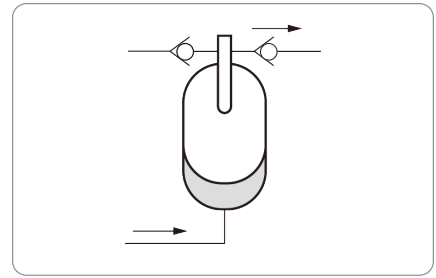

4. Shock Dampening

Rapid opening and closing of valves can create shock waves in a hydraulic system. These shock conditions can create noise, damage, and premature failure to hoses, fittings, and other components.

An Accumulator can be used to eliminate the shock in a hydraulic system.

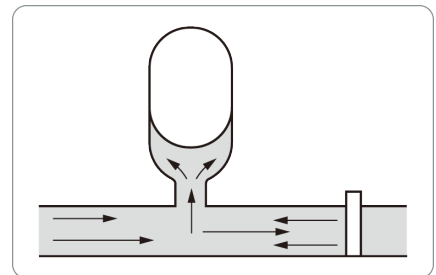

5. Pulsation Dampening

To obtain efficiencies of “energy storage”, “shock dampening”, and “pulsation dampening” at the same time, an Accumulator with “Super Pulse Damper” or “Pulse Damper” is suitable.

An Accumulator can be used to dampen shocks and pulsations caused by pumps, protect a hydraulic system from surge and vibration, and eliminate noise. An in-line type Accumulator is most effective for pulsation dampening application.

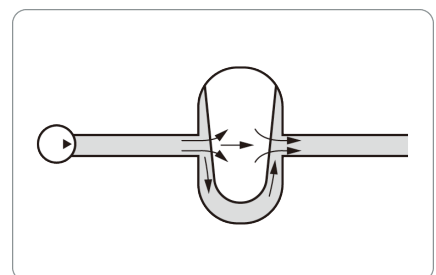
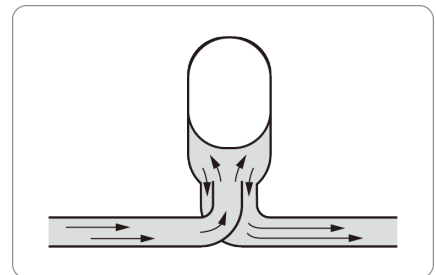

A280

series

Piston Accumulators 活塞式蓄壓器

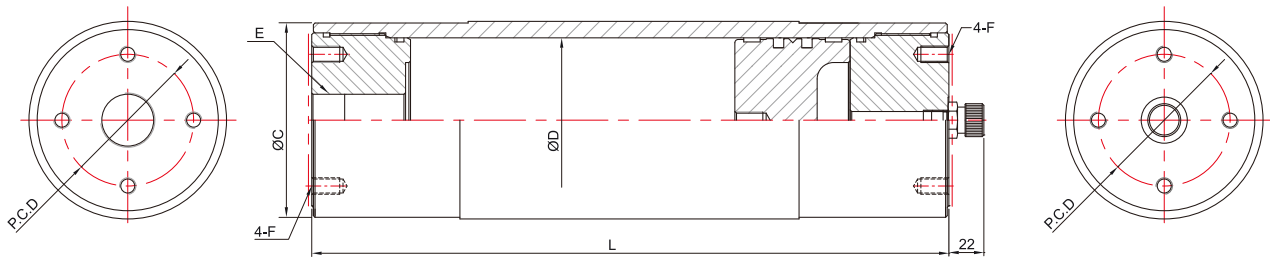

MODEL CODE

SERIES

A=Piston Accumulators

MAX WORKING PRESSURE(bar)

280=280bar

MATERIAL OF SEALS

S=NBR/PTFE compound

V=FKM/PTFE compound

PISTON DIAMETER

08=80mm

10=100mm

16=160mm

18=180mm

25=250mm

CERTIFICATE CODE

U=PED 2014/68/EU

NOMINAL VOLUME(LITRE)

20=20L

FLUID CONNECTION

S=Standard

GAS SIDE CONNECTION

S=Standard

PRE-CHARGE PRESSURE (bar)

000=0bar

030=30bar

A 280 - S - 16 - U - 20 - S S - 000

SPECIAL SIZES AND SPECIAL VERSIONS ON REQUEST.

DIMENSION

LITRE	L	ØC	ØD	E	F	P.C.D
0.5	270	95	80	G 3/4	M10X1.5	60
1	370	95	80	G 3/4	M10X1.5	60
2	570	95	80	G 3/4	M10X1.5	60
3	770	95	80	G 3/4	M10X1.5	60
4	970	95	80	G 3/4	M10X1.5	60
5	1170	95	80	G 3/4	M10X1.5	60
2	450	120	100	G 1	M10X1.5	80
3	580	120	100	G 1	M10X1.5	80
4	710	120	100	G 1	M10X1.5	80
5	840	120	100	G 1	M10X1.5	80
8	1230	120	100	G 1	M10X1.5	80
10	1490	120	100	G 1	M10X1.5	80
10	755	190	160	G 1,1/4	M16X2.0	135
15	1005	190	160	G 1,1/4	M16X2.0	135
20	1255	190	160	G 1,1/4	M16X2.0	135
25	1505	190	160	G 1,1/4	M16X2.0	135
30	1755	190	160	G 1,1/4	M16X2.0	135
40	2255	190	160	G 1,1/4	M16X2.0	135
10	670	216	180	G 1,1/4	M16X2.0	150
15	870	216	180	G 1,1/4	M16X2.0	150
20	1070	216	180	G 1,1/4	M16X2.0	150
25	1270	216	180	G 1,1/4	M16X2.0	150
30	1470	216	180	G 1,1/4	M16X2.0	150
40	1870	216	180	G 1,1/4	M16X2.0	150
30	965	299	250	G 1,1/2	M16X2.0	210
40	1170	299	250	G 1,1/2	M16X2.0	210
50	1375	299	250	G 1,1/2	M16X2.0	210
60	1580	299	250	G 1,1/2	M16X2.0	210
80	1990	299	250	G 1,1/2	M16X2.0	210
100	2400	299	250	G 1,1/2	M16X2.0	210

TECHNICAL DATA

Operating pressure : Max.280bar

Operating temperature : NBR -30°C to +80°C

Mounting type : any position

STANDARD CONSTRUCTION CHARACTERISTICS

Gas connection valve : 5/8"-18UNF

Painting : anti-rust primer

Test : standard factory tested

Piston speed : standard 1m/s

ASHUN piston accumulators consist of :

- A cylinder with very finely machined internal surface.
- End caps on the gas side and the oil side. Sealed with O-rings.
- A floating steel or aluminium piston.
- A sealing system adapted to the particular application. The piston floats on two guide rings which prevent metal-to-metal contact between the piston and the accumulator wall. Suitable materials are also available for low temperature applications.

B250

series

Piston Accumulators 活塞式蓄壓器

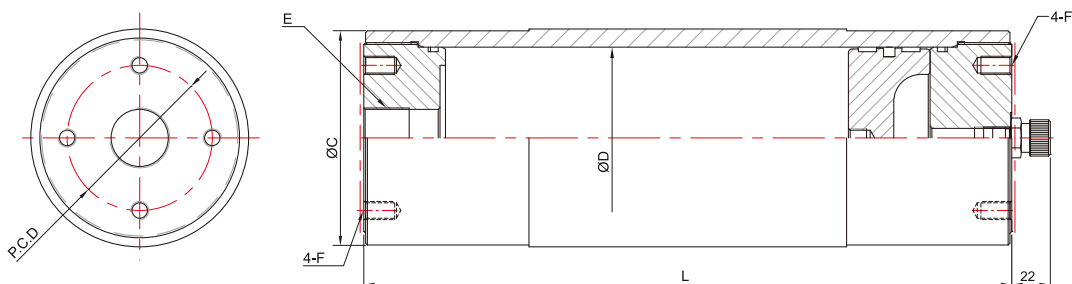

MODEL CODE

SERIES

B=Piston Accumulators

MAX WORKING PRESSURE(bar)

250=250bar

MATERIAL OF SEALS

S=NBR/PTFE compound

V=FKM/PTFE compound

PISTON DIAMETER

08=80mm

10=100mm

16=160mm

25=250mm

CERTIFICATE CODE

U=PED 2014/68/EU

NOMINAL VOLUME(LITRE)

20=20L

FLUID CONNECTION

S=Standard

GAS SIDE CONNECTION

S=Standard

PRE-CHARGE PRESSURE (bar)

000=0bar

030=30bar

B 250 - S - 16 - U - 20 - S S - 000

SPECIAL SIZES AND SPECIAL VERIONS ON REQUEST.

DIMENSION

LITRE	L	ØC	ØD	E	F	P.C.D
0.5	225	95	80	G 3/4	M10X1.5	60
1	325	95	80	G 3/4	M10X1.5	60
2	525	95	80	G 3/4	M10X1.5	60
3	725	95	80	G 3/4	M10X1.5	60
4	925	95	80	G 3/4	M10X1.5	60
5	1125	95	80	G 3/4	M10X1.5	60
2	390	120	100	G 1	M10X1.5	80
3	520	120	100	G 1	M10X1.5	80
4	650	120	100	G 1	M10X1.5	80
5	780	120	100	G 1	M10X1.5	80
8	1170	120	100	G 1	M10X1.5	80
10	1430	120	100	G 1	M10X1.5	80
10	700	190	160	G 1,1/4	M16X2.0	135
15	950	190	160	G 1,1/4	M16X2.0	135
20	1200	190	160	G 1,1/4	M16X2.0	135
25	1450	190	160	G 1,1/4	M16X2.0	135
30	1700	190	160	G 1,1/4	M16X2.0	135
40	2200	190	160	G 1,1/4	M16X2.0	135
30	895	299	250	G 1,1/2	M16X2.0	210
40	1100	299	250	G 1,1/2	M16X2.0	210
50	1305	299	250	G 1,1/2	M16X2.0	210
60	1510	299	250	G 1,1/2	M16X2.0	210
80	1920	299	250	G 1,1/2	M16X2.0	210
100	2330	299	250	G 1,1/2	M16X2.0	210

TECHNICAL DATA

Operating pressure : Max.250bar

Operating temperature : NBR -30°C to +80°C

Mounting type : any position

STANDARD CONSTRUCTION CHARACTERISTICS

Gas connection valve : 5/8"-18UNF

Painting : anti-rust primer

Test : standard factory tested

Piston speed : standard 0.5m/s

油順活塞式蓄壓器包含下列元件：

- 精密加工的本體，內部表面經過多道程序加工以降低活塞移動摩擦力。
- 兩側端蓋能有效防止氣體洩漏及空氣中水氣進入。
- 高精度活塞作為把容器內氣體和液壓油分離的分離器。
- 油封系統能夠避免作動時金屬之間(活塞與管壁)的摩擦，並可以符合低溫環境應用。
- 氣室備有充氣閥(與輪胎的充氣閥相當的控制閥)，油室備有液壓油的出入口。

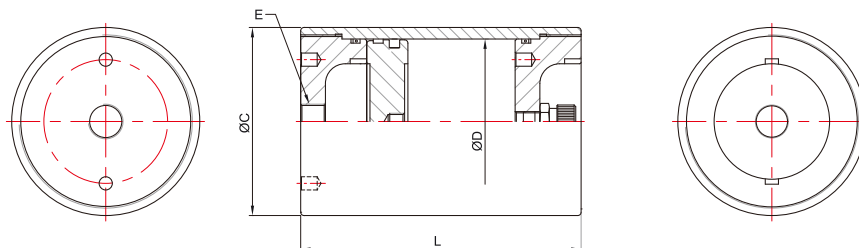

MODEL CODE

SERIES

C=Piston Accumulator

C 210 - S - 10 - U - 03 - S S - 000

MAX WORKING PRESSURE(bar)

210=210bar

MATERIAL OF SEALS

S=NBR/PU

Q=NBR/PTFE compound

V=FKM/PTFE compound

PISTON DIAMETER

10=100mm

15=150mm

CERTIFICATE CODE

U=PED 2014/68/EU

NOMINAL VOLUME(LITRE)

03=0.3L **05**=0.5L **07**=0.7L **10**=1.0L **15**=1.5L

20=2.0L **25**=2.5L **30**=3.0L **35**=3.5L **40**=4.0L

FLUID CONNECTION

S=Standard

GAS SIDE CONNECTION

S=Standard

PRE-CHARGE PRESSURE (bar)

000=0bar

030=30bar

SPECIAL SIZES AND SPECIAL VERIONS ON REQUEST.

DIMENSION

LITRE	L	ØC	ØD	E
0.3	145	114	100	G 1/2
0.5	170	114	100	G 1/2
0.7	195	114	100	G 1/2
1	235	114	100	G 1/2
1.5	300	114	100	G 1/2
2	255	168	150	G 3/4
2.5	285	168	150	G 3/4
3	310	168	150	G 3/4
3.5	340	168	150	G 3/4
4	370	168	150	G 3/4

TECHNICAL DATA

Operating pressure : Max.210bar

Operating temperature : NBR -30°C to +80°C

Mounting type : any position

STANDARD CONSTRUCTION CHARACTERISTICS

Gas connection valve : 5/8"-18UNF

Painting : anti-rust primer

Test : standard factory tested

Piston speed : standard 0.5m/s

The information in this brochure relates to the operating conditions and applications described. For applications and operating onditions not described, please contact the relevant technical department. We reserve the right to technical modifications.

本型錄所標示的應用資訊涉及到的工作條件和應用，對於操作程序條件沒有說明之處請與我們相關技術部門聯繫，保留技術上的更改之權利。

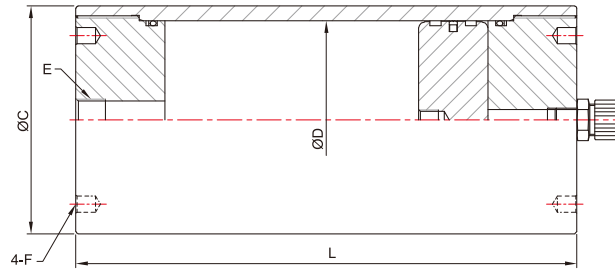
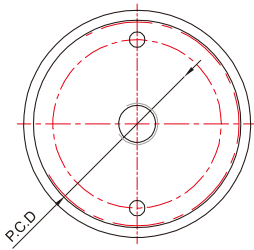

MODEL CODE

SERIES D=Piston Accumulators	D 260 - Q - 08 - U - 10 - S S - 000					
MAX WORKING PRESSURE(bar) 150=150bar=PISTON DIAMETER 100mm 260=260bar						
MATERIAL OF SEALS S=NBR/PU Q=NBR/PTFE compound V=FKM/PTFE compound						
PISTON DIAMETER 04=40mm 05=50mm 08=80mm 10=100mm						
CERTIFICATE CODE U=PED 2014/68/EU						
NOMINAL VOLUME(LITRE) 002=0.02L 005=0.05L 01=0.1L 02=0.2L 03=0.3L 05=0.5L 07=0.7L 10=1L 15=1.5L 20=2L 25=2.5L 30=3L						
FLUID CONNECTION S=Standard						
GAS SIDE CONNECTION S=Standard						
PRE-CHARGE PRESSURE (bar) 000=0bar 030=30bar						

SPECIAL SIZES AND SPECIAL VERIONS ON REQUEST.

DIMENSION

LITRE	L	ØC	ØD	E	F	P.C.D
0.02	96	50	40	G 3/8	Ø 6.1	30
0.05	120	50	40	G 3/8	Ø 6.1	30
0.1	160	50	40	G 3/8	Ø 6.1	30
0.2	240	50	40	G 3/8	Ø 6.1	30
0.3	320	50	40	G 3/8	Ø 6.1	30
0.5	480	50	40	G 3/8	Ø 6.1	30
0.1	141	60	50	G 3/8	Ø 6.1	40
0.2	192	60	50	G 3/8	Ø 6.1	40
0.3	243	60	50	G 3/8	Ø 6.1	40
0.5	345	60	50	G 3/8	Ø 6.1	40
0.7	447	60	50	G 3/8	Ø 6.1	40
1	600	60	50	G 3/8	Ø 6.1	40
0.3	170	95	80	G 1/2	Ø 8.1	65
0.5	210	95	80	G 1/2	Ø 8.1	65
0.7	250	95	80	G 1/2	Ø 8.1	65
1	310	95	80	G 1/2	Ø 8.1	65
1.5	410	95	80	G 1/2	Ø 8.1	65
2	510	95	80	G 1/2	Ø 8.1	65
0.5	177	114	100	G 1/2	Ø 8.1	85
1	241	114	100	G 1/2	Ø 8.1	85
1.5	305	114	100	G 1/2	Ø 8.1	85
2	369	114	100	G 1/2	Ø 8.1	85
2.5	433	114	100	G 1/2	Ø 8.1	85
3	497	114	100	G 1/2	Ø 8.1	85

TECHNICAL DATA

Operating pressure : Max.260bar
 Operating temperature : NBR -30°C to +80°C
 Mounting type : any position
 Note : Piston diameter 100mm only limited to pressure 150 bar

STANDARD CONSTRUCTION CHARACTERISTICS

Gas connection valve : 5/8"-18UNF
 Painting : anti-rust primer
 Test : standard factory tested
 Piston speed : standard 0.5m/s

STANDARD CONSTRUCTION CHARACTERISTICS

- D260 series is ideal for light applications.
- Excellent dynamic sealing performance can continue to maintain low friction operation.
- Excellent extrusion resistance.
- Preferred option for media separation, such as fluid and gas.
- High cost performance.

特點和優勢

- D260 系列非常適合輕型應用。
- 卓越的動態密封性能可持續保持低摩擦運行。
- 出色的抗擠壓性。
- 介質分離的首選選項，例如液體和氣體。
- 高性價比。

CHARGER

■ STANDARD CHARGER 標準充氣閥

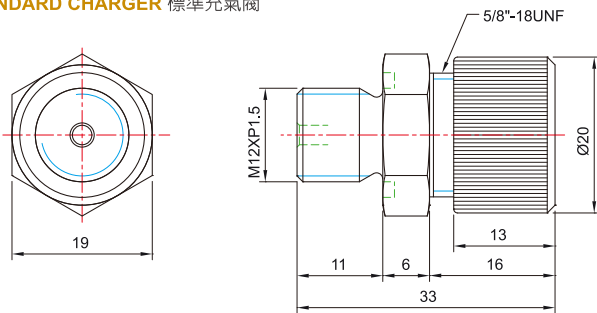

STANDARD CONSTRUCTION CHARACTERISTICS

- Operating pressure : Max.280bar.
 - Gas connection port thread : 5/8"-18UNF
 - Painting : anti-rust primer
 - Test : standard factory tested
 - Description : STANDARD CHARGER
- Not only can provide gas filling and discharge function, but also effectively prevent gas leakage.

標準充氣閥可提供氣體充填及排放功能，能有效防止氣體洩漏。

■ Pressure gauge model 壓力計轉接頭

GAS Side connection on the piston accumulator for permanent monitoring of the pre-charge pressure

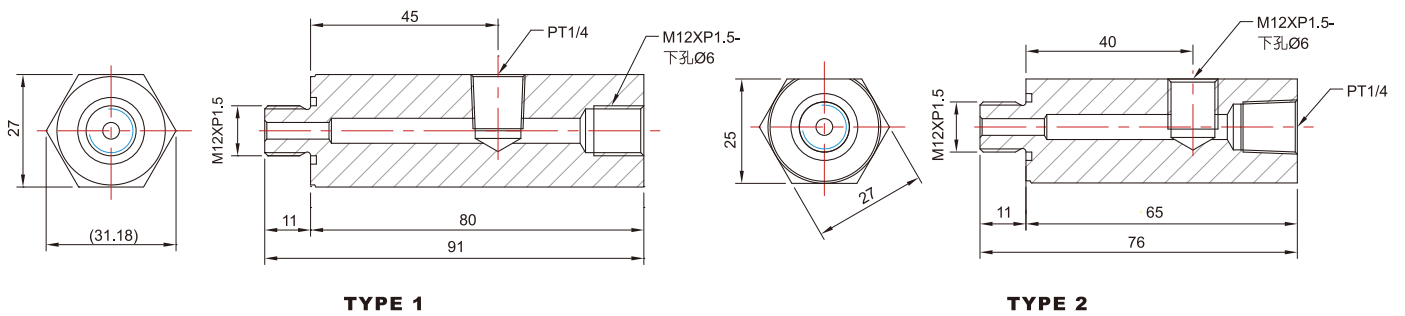

ASHUN

ASHUN FLUID POWER CO., LTD.

No. 18, Jingke S. Rd., Nantun Dist., Taichung City 40852, Taiwan

TEL: +886-4-23505599

FAX: +886-4-23505511

E-mail: info@ashun.com



www.ashun.com